



PRODUCT SPECIFICATION

Model No: CSLO-N34XTG1-A0RT

Descriptions:	
■	Product Type : Superbright Lamp
■	LED Package : Oval LED Lamp
■	Emitting Color : Green
■	Viewing Angle : 100°/50°
■	Stopper :



CUSTOMER APPROVED SIGNATURES	APPROVED BY	CHECKED BY	PREPARED BY
			

OPTO PLUS TECHNOLOGIES CO.,LTD

Address : No.696, Yangming North Rd., ShaoXing

City,ZheJiang Province,P.R.China

Tel : 86-575-88623888

Fax : 86-575-88623112

<http://www.csbright.com>

Model No.: CSLO-N34XTG1-A0RT

■ **Feature**

1. Low Power Consumption.
2. Wave soldering process compatible.
3. RoHS compliant.

■ **Device Selection Guide**

Part No.	Chip	Color	
	Material	Emitted	Resin
CSLO-N34XTG1-A0RT	InGaN	Green	Green Diffusion

■ **Applications**

1. Amusement
2. Architecture and entertainment lighting
3. Electronic signs and signals.

Model No.: CSLO-N34XTG1-A0RT

■ **Absolute Maximum Ratings**

Parameter	Symbol	Rating	Unit
Power Dissipation	Pd	108	mW
Continuous Forward Current	I _f	30	mA
Reverse Voltage* ¹	V _r	5	V
Peak Forward Current (Duty Cycle 1/10,1KHz)* ²	I _{fP}	100	mA
ESD Sensitivity	ESD	1000	V
LED Junction Temperature* ³	T _j	110	°C
Operating Temperature.	T _{opr}	-40~ +80°C	
Storage Temperature.	T _{stg}	-40 ~ +100°C	
Lead Soldering Temperature	T _{sol}	Max. 260 for 5 sec Max. (3mm from the epoxy body)	

Note:

1. The device can not operated under continuous reverse voltage.
2. Pulse width \leq 0.1 msec, duty \leq 1/10
3. Proper current rating must be observed to maintain junction temperature below the maximum at all the time.

Model No.: CSLO-N34XTG1-A0RT

Electrical / Optical Characteristics

Parameter	Symbol	Min	Typ	Max	Unit	Condition
Forward Voltage	V_f	-----	3.0	3.6	V	If = 20mA
Luminous Intensity*	I_v	1800	3000	-----	mcd	
Dominant Wavelength	λ_d	-----	522	-----	nm	
Spectrum Radiation Bandwidth	$\Delta\lambda$	-----	30	-----	nm	
Viewing Angle	$2\theta_{1/2}$	----	100/50	-----	Deg	
Reverse Current	I_r	-----	-----	50	μA	Vr = 5V
ESD Sensitivity	HBM	-----	-----	1000	V	MIL-STD-833G

* Luminous intensity value is traceable to CIE127-2007 standards

Package Outline Dimensions

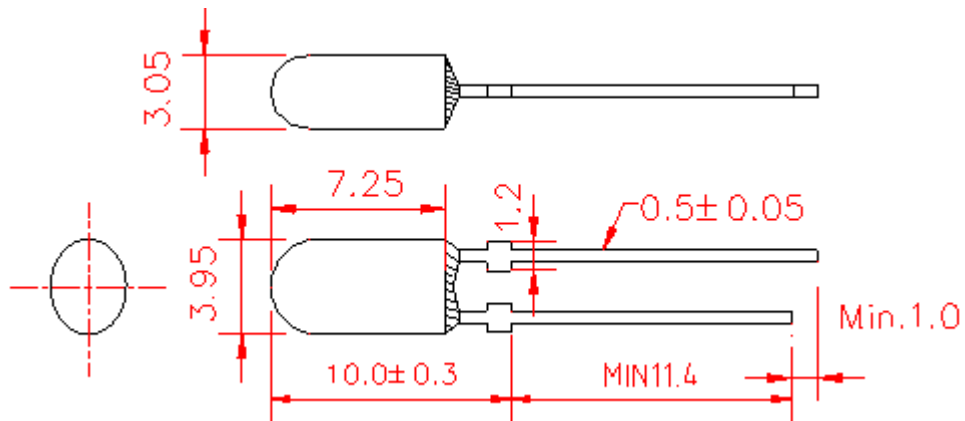

* Tolerance: ± 0.25 Unit: mm

Model No.: CSLO-N34XTG1-A0RT

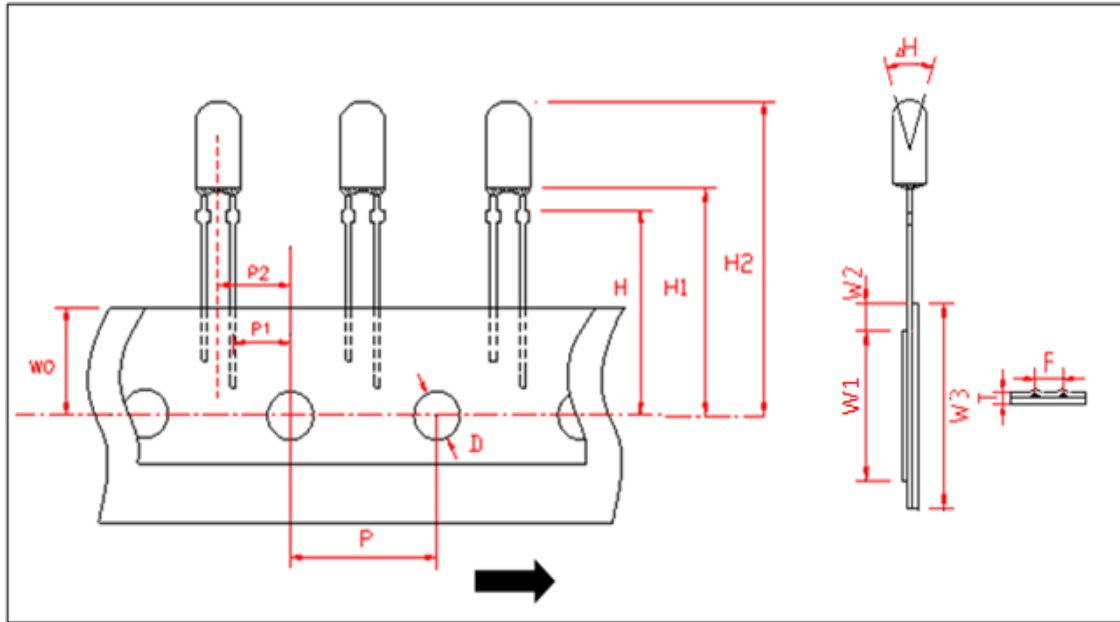

SYMBOL	SPECIFICATION			
	MILLIMETER		INCH	
	SIZE	TOLERANCE	SIZE	TOLERANCE
D	4	±0.2	0.157	±0.008
F	2.54	±0.5	0.100	±0.020
Δ H		MAX.2.0		MAX.0.079
H		±0.5		±0.020
H1	18.75	±0.5	0.738	±0.020
H2	26.0	±0.5	1.024	±0.020
P	12.7	±0.3	0.5	±0.012
P1	5.08	±0.7	0.200	±0.028
P2	6.35	±1.3	0.25	±0.051
T		MAX.1.42		MAX.0.056
WO	9	±0.5	0.354	±0.020
W1	13	±0.5	0.512	±0.020
W2		MAX.2.0		MAX.0.079
W3	18	±0.5	0.709	±0.020
M		±0.5		±0.020

Model No.: CSLO-N34XTG1-A0RT

■ **Luminous Intensity Rank Limits ($I_f = 20\text{mA}$)**

Luminous Intensity				
Bin Code	Min	Max	Unit	Condition
30	1800	2300	mcd	$I_f = 20\text{mA}$
31	2300	3000		
32	3000	3900		
33	3900	5100		

■ **Dominant Wavelength Rank Limits ($I_f = 20\text{mA}$)**

Dominant Wavelength				
Bin Code	Min	Max	Unit	Condition
TG1	515	520	nm	$I_f = 20\text{mA}$
TG2	520	525		
TG3	525	530		

■ **Forward Voltage Rank Limits ($I_f = 20\text{mA}$)**

V_f Rank				
Bin Code	Min	Max	Unit	Condition
H	2.8	3.0	v	$I_f = 20\text{mA}$
J	3.0	3.2		
K	3.2	3.4		
L	3.4	3.6		

Notes:

1. Tolerance of measurement of luminous intensity : $\pm 15\%$;
2. Tolerance of measurement of dominant wavelength: $\pm 2\text{nm}$;
3. Tolerance of measurement of forward voltage: $\pm 0.1\text{v}$;
4. All data are measured by OPT's test equipment.
5. One delivery will include several color rank, VF rank and I_v ranks of the products.
6. The quantity-ratio of the ranks is decided by OPT.

Model No.: CSLO-N34XTG1-A0RT

Electrical / Optical Characteristics Curves (Ta = 25°C Unless Otherwise Noted)

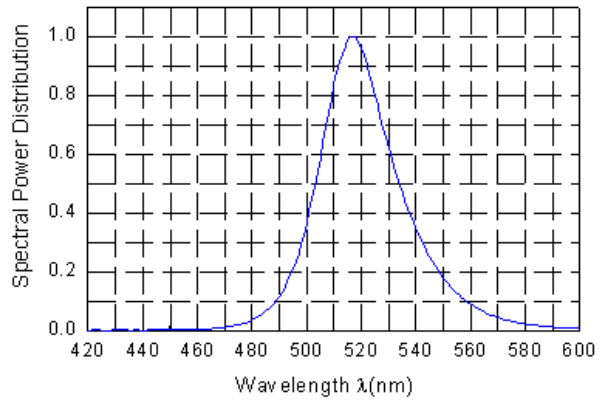
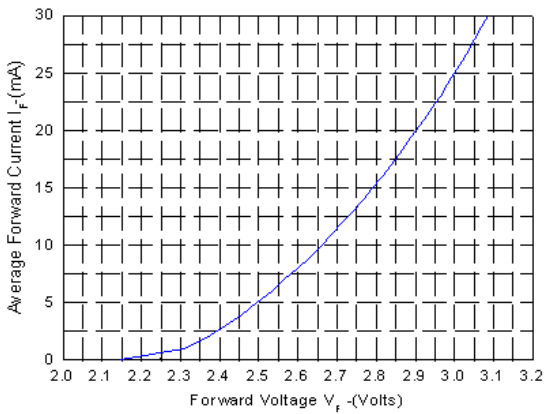

Figure1. Forward Current VS. Forward Voltage Figure2. Spectral Power Distribution vs. Wavelength

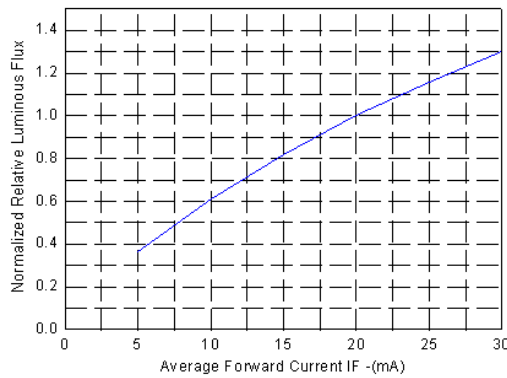

Figure3. Relative Luminous Intensity vs. Forward Current

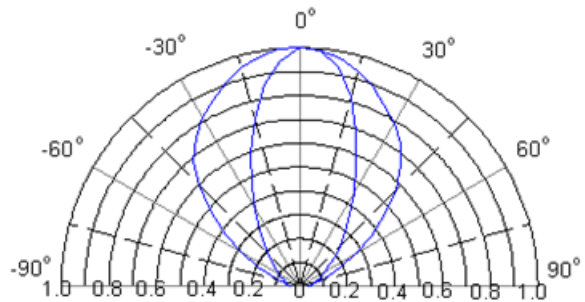
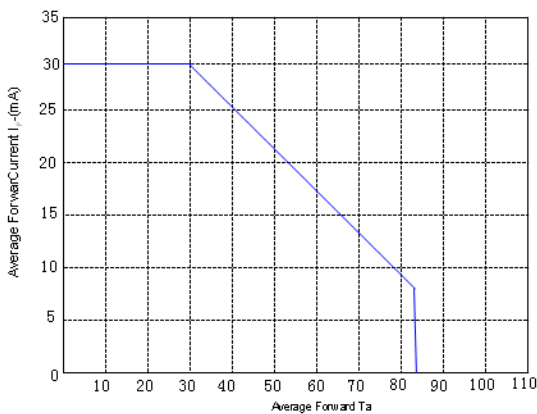

Figure4. Forward Current vs. Ambient Temperature Figure5. Relative Luminosity VS. Radiation Angle

Model No.: CSLO-N34XTG1-A0RT

■ Precautions For Use

1. Wave Soldering Profile

.Distance : 1.6 mm min (From seating plane)

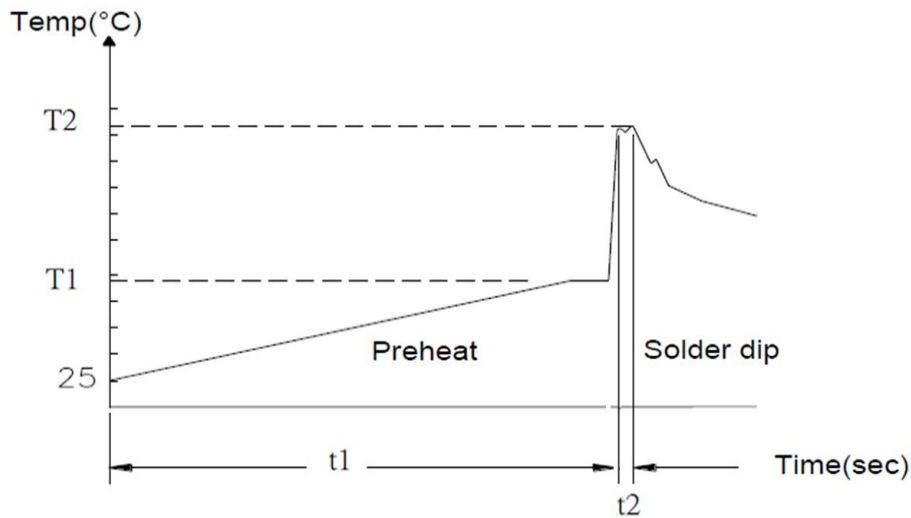

Item	Condition		Notes
Preheat	Temp. T1	120-180 °C	PWB temperature (soldering side surface)
	time t1	60-180 sec	
Solder Dip	Temp. T2	230-260 °C	Bath temperature
	time t2	2-4 sec	Solder tank passage time

2. Hand Soldering (Iron Condition)

- 2.1 Soldering Iron: 30W Max
- 2.2 Temperature 350°C Max (iron tip 260°C Max)
- 2.3 Soldering Time: 3 Seconds Max (Once)
- 2.4 Distance: 1.6mm min (From seating plane)

Model No.: CSLO-N34XTG1-A0RT

3. Static Electricity

3.1 Static electricity or surge voltage damages LEDs.

It is recommended that a wrist band or an anti-electrostatic glove should be used when handling the LEDs.

3.2 All devices, equipment and machinery must be properly grounded. It is recommended that measures be taken against surge voltage to the equipment that mounts the LEDs.

4. Storage

4.1 Shelf life: Within 18 months under following conditions.

Un-opened, at normal temperature / Normal relative humidity (+5~+30°C / 70%Rh.max.).

■ Reliability Test Program/ Reliability Test Item Tests and Results

NO.	Test Item	Standard Test Method	Test Conditions	Test Duration	Failure Criteria	Units Failed/Tested
1	OPERATION LIFE	JESD22-A108	Ta= UNDER ROOM TEMPERATURE IF=20MA	1000HRS	#2	0/20
2	HIGH TEMPERATURE HIGH HUMIDITY BURN-IN	JEITA ED-4701/102A MIL-STD-750 1026 MIL-STD-830 1005	Ta=85°C RH= 85% IF=5MA	1000HRS	#2	0/20
3	LOW TEMPERATURE STORAGE	JEITA ED-4701/202A MIL-STD-750 1026 MIL-STD-830 1005	Ta= -55±5°C	1000HRS	#1	0/20
5	SOLDERABILITY	JEITA ED-4701/303A MIL-STD-202(210F)	LEAD FREE:T.sol= 245 ± 5°C(SnCu) DWELL TIME= 5± 1secs		#3	0/20

Notes:

Measurements are performed after allowing the LEDs to return to room temperature.

Model No.: CSLO-N34XTG1-A0RT

● **Failure Criteria**

Criteria #	Items	Conditions	Failure Criteria
#1	Forward Voltage(VF)	IF=20mA	>U.S.L.X1.1
	Luminous Intensity(IV)	IF=20mA	<L.S.L.X0.7
#2	Forward Voltage(VF)	IF=20mA	>U.S.L.X1.1
	Luminous Intensity(IV)	IF=20mA	<L.S.L.X0.5
#3	Solderability		Less than 95% solder coverage

U.S.L.: Upper Specification limit L.S.L.: Lower Specification Limit

■ **Package –**

Package Name	Package Dimension		Distribution of the layer or box		Total Mount	
	Size	Unit	Amount	Unit	Amount	Unit
Bag	327*330	mm	1	Bag	2500	PCS
Inner Box	330*243*50	mm	1	Box	2500	PCS
Outer Box	530*345*290	mm	1	Box	25000	PCS

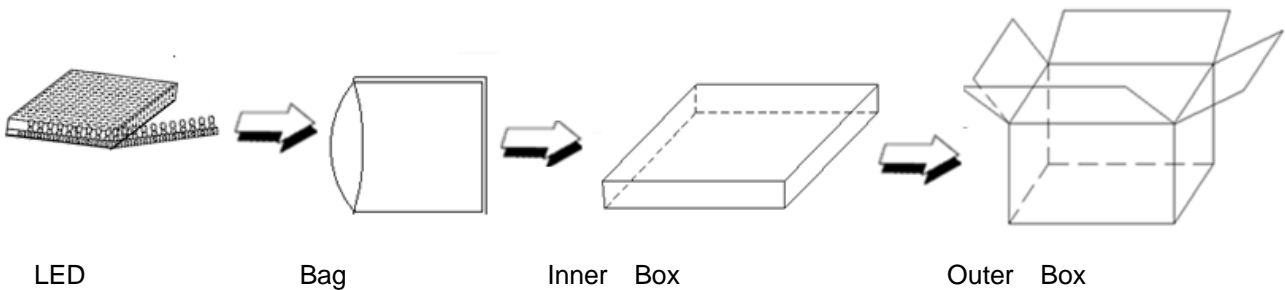

Model No.: CSLO-N34XTG1-A0RT

■ Change story-

Rev.	Date	Change Description
A	2014-12-25	Original version
B	2015-04-28	Appearance size change
C	2018-02-02	Add test standard description
D	2019-09-20	Add remarks on rated specifications.
E	2023-03-15	Delete CS bright corporation's address;

Please confirm with CSB salesman, if your request different from standard specification.