

PRODUCT SPECIFICATION

Model No.: CSDM-16100X CSDM-16101X

Descriptions:
<ul style="list-style-type: none"> ■ 1.5 Inch Dot-Matrix Display ■ 16*16Array with X-Y Select ■ CSDM-16100 is Common Column Cathode ■ CSDM-16101 is Common Column Anode ■ Emitting Color: Pure Green; Yellow Green; Yellow; Amber; Orange; Red; Deep Red ■ Standard: -1W: Gray face, white Dot. -2W: Black face, white Dot.



CUSTOMER APPROVED SIGNATURES	APPROVED BY	CHECKED BY	PREPARED BY

OPTO PLUS TECHNOLOGIES CO.,LTD
 Address:No.696,Yangming North Rd,
 ShaoXing City,ZheJiang Province, P.R.China.
 Tel :86-575-88623888
 Fax:86-575-88623112

Model No.: CSDM-16100X CSDM-16101X

■ Features -

1. 1.5 inch (39.2mm) Matrix height.
2. Air type.
3. RoHS compliant.
4. Low power consumption.
5. Easy mounting on P.C. board or socket.

■ Device Selection Guide -

Model No.	Chip	
	Material	Emitting Color
CSDM-1610x2	InGaN AlGaInP	Pure Green
CSDM-1610xM		Yellow Green
CSDM-1610xT		Yellow
CSDM-1610xA		Amber
CSDM-1610xV		Orange
CSDM-1610xL		Red
CSDM-1610xU		Deep Red

■ LED Numeric/Alphanumeric Display

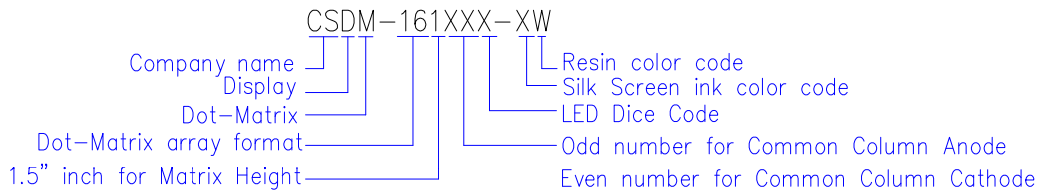

■ Mechanical Dimensions -

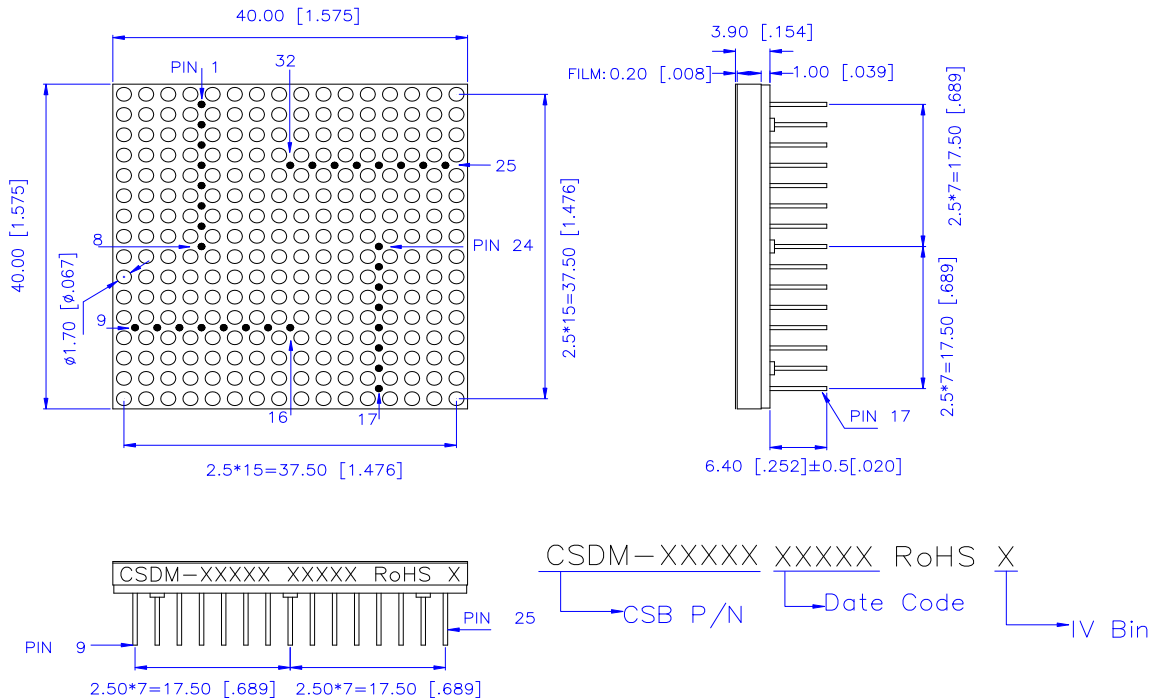

Notes:

1. All pins are $\Phi 0.51 [0.020] \pm 0.1 [0.004]$
2. Dimension in millimeter [inch], tolerance is $\pm 0.25 [0.010]$ and angle is $\pm 1^\circ$ unless otherwise noted.
3. Bending \leq Length * 1%.

Model No.: CSDM-16100X CSDM-16101X

■ All Light On Segments Feature & Pin Position

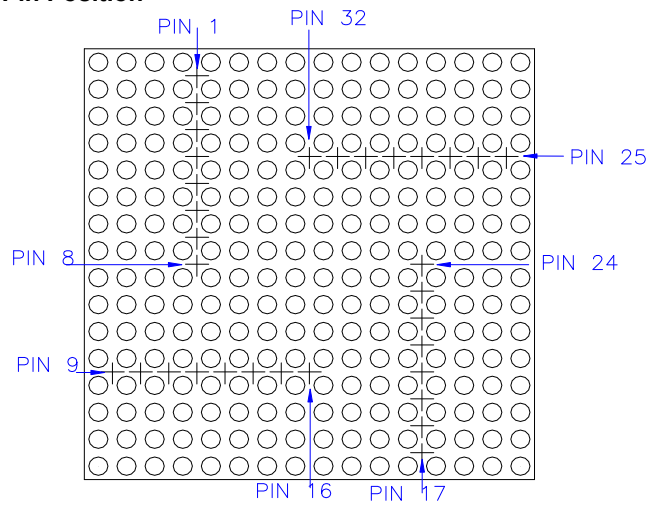

■ Internal Circuit Diagrams -

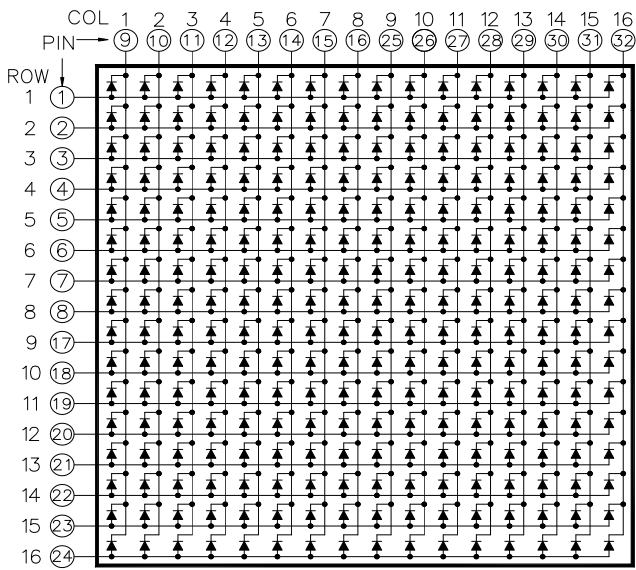

CSDM-16100 Common Column Cathode

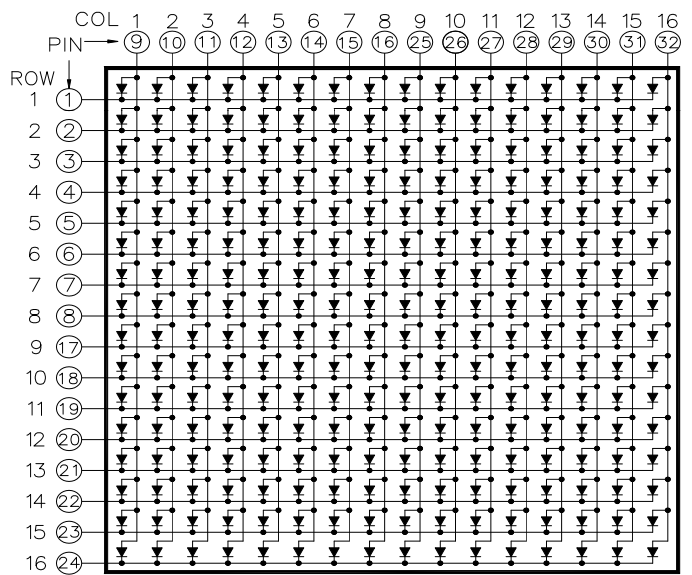

CSDM-16101 Common Column Anode

Model No.: CSDM-16100X CSDM-16101X

■ Absolute Maximum Rating -

(Ta=25°C)

Parameter	Symbol	Rating		Unit
		M/T/A/V/L/U	2	
Power Dissipation Per Dice	P _{AD}	70	114	mW
Derating Liner from 25°C per Dice	-	0.33	0.4	mA/°C
Continuous Forward Current Per Dice	I _{AF}	25	30	mA
Peak Current Per Dice(duty cycle 1/10,1KHz)	I _{PF}	90	100	mA
Reverse Voltage Per Dice	VR	5	5	V
Electrostatic discharge(HBM)	ESD	/	1000	V
Operating Temp.	T _{opr}	-35 ~ +85		°C
Storage Temp.	T _{stg}	-35 ~ +85		°C
Hand Soldering Temp.	T _{sol}	350		°C

■ Electro-optical Characteristics -

(Ta=25°C)

Parameter	Symbol	Chip	Min.	Typ.	Max.	Unit	Condition
Luminous Intensity Per Segment	I _v	2	-	210	-	mcd	IF=10mA
		M	-	7	-		
		T	-	48	-		
		A	-	48	-		
		V	-	16	-		
		L	-	28	-		
		U	-	8	-		
Forward Voltage Per Segment	VF	2	-	3.2	3.8	V	IF=20mA
		M/T/A/V/L/U	-	2	2.8		
Peak Emission Wavelength / Dominant Wavelength	λ _P /λ _d	2	-	*525	-	nm	IF=20mA
		M	-	572/570	-		
		T	-	592/590	-		
		A	-	612/605	-		
		V	-	632/625	-		
		L	-	644/630	-		
		U	-	660/645	-		
Reverse Current	I _R		-	-	100	μA	VR=5V
Luminous Intensity Matching Ratio	IV-m		-	-	2:1	-	*1

Notes: *1 Condition is I_p=80mA 1/16Duty

Model No.: CSDM-16100X CSDM-16101X

Electrical / Optical Characteristics Curves -

(Ta = 25°C Unless Otherwise Noted)

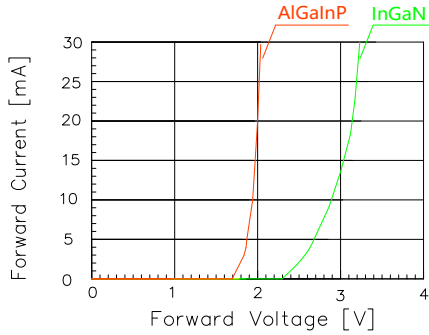

Fig 1. Forward Current vs. Forward Voltage

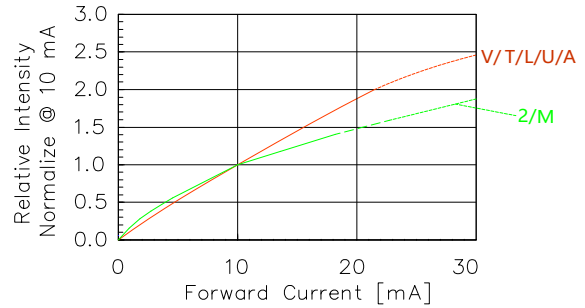

Fig 2. Relative Intensity vs. Forward Current

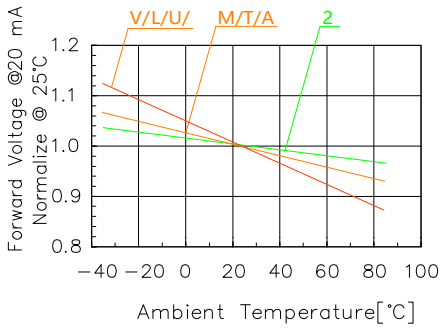

Fig 3. Forward Voltage vs. Temperature

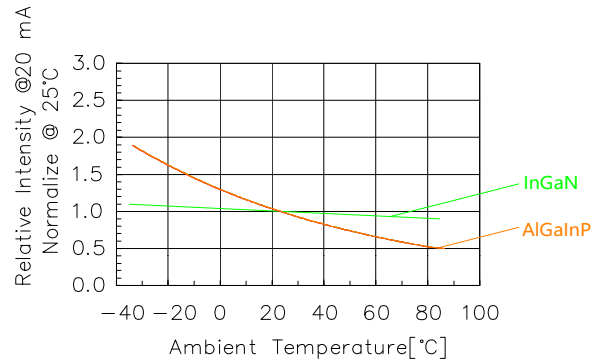

Fig 4. Relative Intensity vs. Temperature

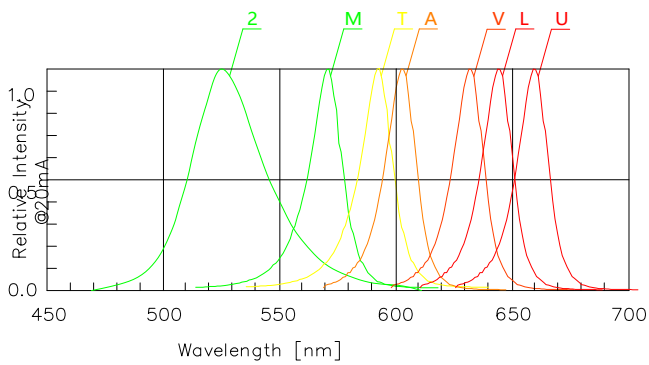

Fig 5. Relative Intensity vs. Wavelength

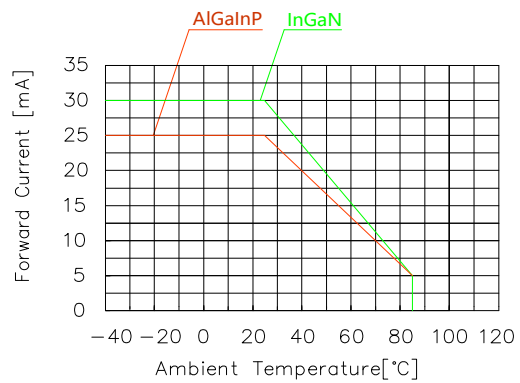

Fig 6. Forward current vs. Temperature

Model No.: CSDM-16100X CSDM-16101X

■ Precautions For Use -

1.Wave Soldering Profile

Distance:1.6mm min(From seating plane)

Item	Condition		Note
Preheat	Temperature T1	80 – 120°C	PWB temperature (Soldering side surface)
	Time t1	60 – 180sec	
Solder Dip	Temperature T2	230 – 260°C	Bath temperature
	Time t2	2 – 4sec	Solder tank passage time

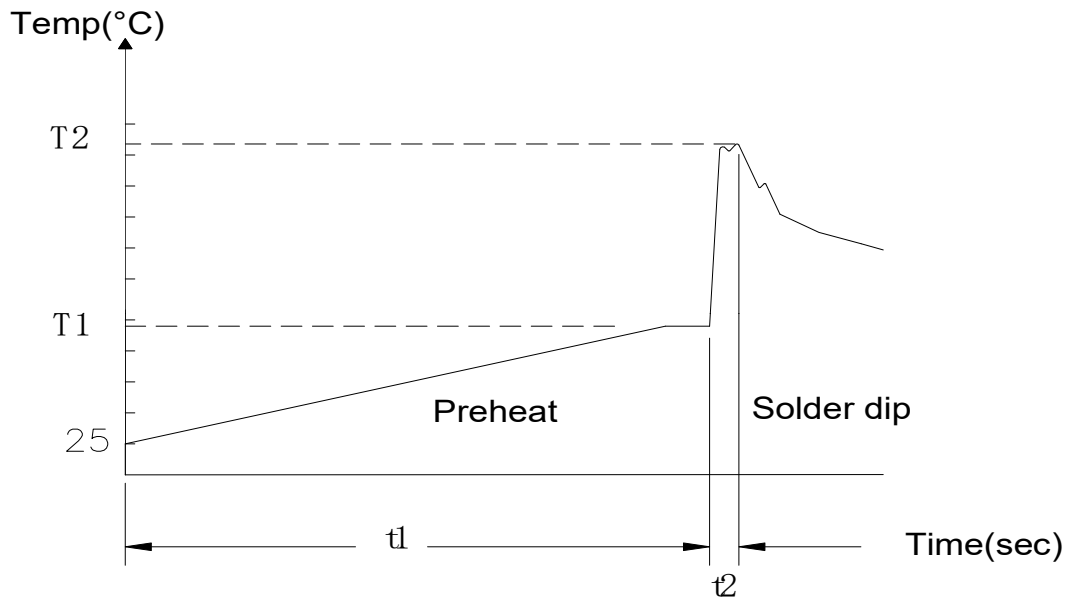

2.Hand Soldering (Iron Condition)

Soldering Iron:30W Max

Temperature 350°C Max

Soldering Time:3 Seconds Max(One Time)

Distance:1.6mm min(From seating plane)